

KAYO MOTO

KT250

Assembly Manual



WWW.KAYOMOTO.COM

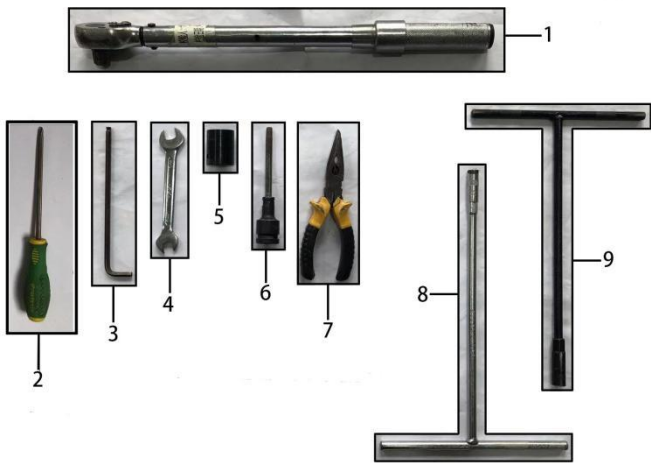

- ① Torque wrench
- ② Phillips screwdriver
- ③ 5mm hexagon wrench
- ④ 10-12mm wrench
- ⑤ 21mm socket
- ⑥ hexagon socket
- ⑦ Needle nose pliers
- ⑧ 8mm socket
- ⑨ 10mm socket

1. Tools for opening and assembling the dirt bike.



2. Remove the straps and cardboard cover.



3. Take out the parts attached to the vehicle and iron frame, remove the iron frame screws, wait for subsequent installation.



| | Name | Quantity |
|---|--------------------------|----------|
| 1 | Handlebar cover | 1 |
| | Handlebar sponge | 1 |
| 2 | Spark plug socket | 1 |
| 3 | Cable tie (handlebar) | 2 |
| 4 | Coolant | 1 |
| 5 | Front wheel assy | 1 |
| 6 | Front mud fender | 1 |
| 7 | Fuel mix ratio container | 1 |
| 8 | Two stroke engine oil | 1 |
| 9 | Front disc brake cover | 1 |

4. The parts shown above need to be installed on the vehicle.



5. Use tool ④⑧ to remove the screw on the left side of headlight, then pull the brake oil pipe out.



6. Remove the cable tie from handlebar. Use tool ①⑥ to tighten the handlebar clamps, tighten evenly, first start by hand tightening all four clamp bolts then (torque: 25-30N.m). Install the lower screw of headlight last.

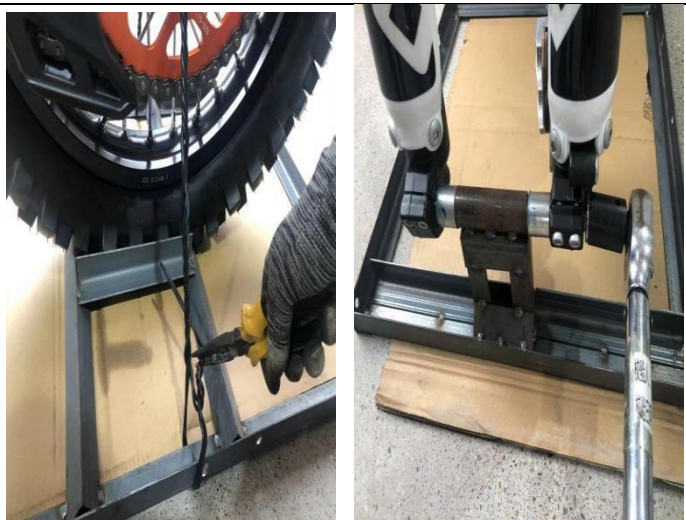

7. Use tool ①⑤⑦ remove the front axle and cut the wire holding the rear wheel.



8. Put the vehicle on the stand for easy installation of other accessories.



9. Install the handlebar cover and sponge on the vehicle.



10. Use tool ⑧ to remove screws of lower clamp assy, then install the front fender and tighten the screws.



11. Remove the plastic wedges between the front brake lever and between the brake pads .



12. Install the front axle then use tool ①⑤ to tighten the fixing nut. (bushings are on the left, torque: 80-90N.m) .



13. Use tool ⑩⑥ to tighten the screws of front shock at the torque of 25-30 N.m.



14. Install the front disc brake cover to the left shock and tighten the screws with tool ③



15. Use tool ⑨ to remove the screws on seat then remove the seat.



16. Put the battery in and use tool ② to install the battery screws (red is positive, black is negative). Use tool ⑨ to install the seat.



17. Use ratio mix jar to mix the 2-stroke oil and fuel at a ratio of 30:1, add it to the fuel tank and tighten the fuel tank cap. Fill the radiator up with coolant and tighten radiator cap.



18. Turn the fuel tank petcock to the position shown above.



19. Please read the user's manual carefully before riding to better understand the performance of the vehicle.